

**ENGINE GUARD KIT  
 INSTALLATION INSTRUCTIONS  
 STR-5KS31-20-00  
 XVS1100 ("V STAR 1100")**



**INTRODUCTION**

Please read and understand these instructions completely before installation to avoid any possible injury to yourself or damage to your motorcycle and/or accessory.

**DEALER:** These instructions contain important information for future reference and must be given to the customer.

PARTS LIST			
Item	Part Name	Description	Qty
①	Engine Guard		1
②	Spacer	Aluminum, 19.1mm OD x 10mm thick	1
③	Spacer	Aluminum, 15.9mm OD x 4.8mm thick	2
④	Bolt, Hex Head Flange	M10 x 1.25p x 70mm long	1
⑤	Bolt, Hex Head Flange	M10 x 1.25p x 20mm long	1
⑥	Bolt, Button Head	M8 x 1.25p x 20mm long	2
⑦	Bolt	Stock part	REF.
⑧	Bolt	Stock part	REF.

**INSTALLATION**

1. Place the motorcycle securely on the side-stand.
2. Remove the two bolts holding the left rider Floorboard assembly to the Frame. These bolts will be reused.

**NOTE:** It is not necessary to disconnect the shift linkage.

3. Remove the forward bolt holding the left side of the front Cylinder Head to the Frame. Store this bolt in case the Engine Guard is removed later.
4. Remove the Forward bolt which holds the right side of the front Cylinder Head to the Frame. Store this Bolt in case the Engine Guard is removed later.

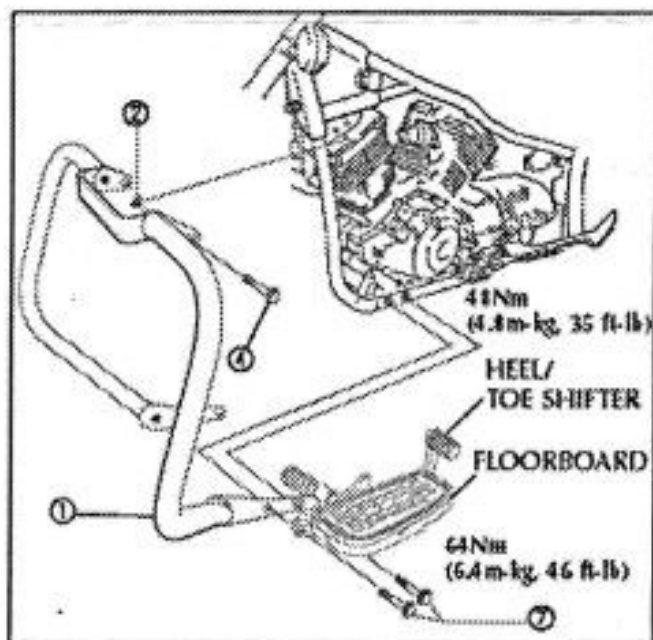

5. Position the wide Spacer behind the upper mounting hole of the Engine Guard ①, then install the new bolt ④ through the Guard and Spacer into the Frame. Loosely tighten the bolts.

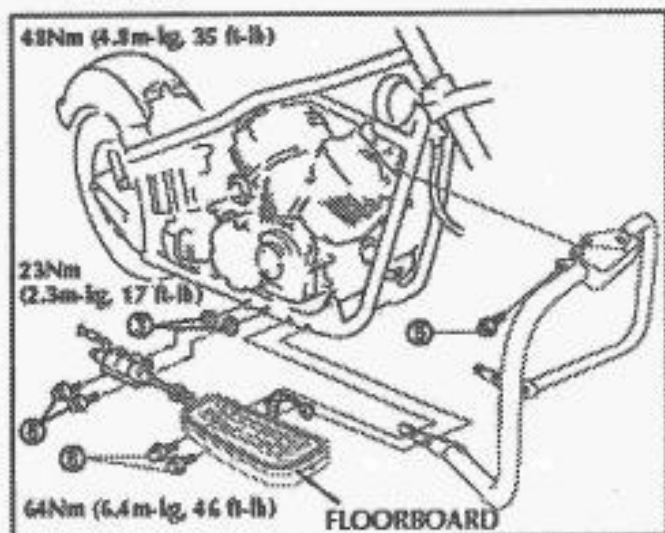

6. Reinstall the left rider Floorboard assembly with the Lower Engine Guard mount between the Frame and the Floorboard. Reinstall the stock mounting Bolts ⑦. Be sure the Engine Guard ① is properly aligned, then tighten all mounting bolts to the torque specification shown.
7. Remove the two bolts holding the right rider Floorboard assembly to the Frame. These bolts will be reused. Also remove the two bolts holding the rear Brake Master Cylinder Bracket to the Frame. Store the Master Cylinder Bracket mounting Bolts in case the Engine Guard is removed later.

**NOTE:** Do not disconnect the Floorboard assembly from the Master Cylinder or disconnect the Brake Switch Lead Wires.

8. Hold the Engine Guard ① in position on the frame, then install the new Bolt ⑤ through the Guard into the Frame. Loosely tighten the bolts.
9. Reinstall the right Floorboard assembly using the stock mounting bolts ⑧. Loosely tighten the bolts.

#### **WARNING**

Be sure the brake switch lead wires are not pinched or under strain.

10. Position the two narrower Spacers ③ between the brake master cylinder bracket and the frame. Install the two new Bolts ⑥. Be sure the Engine Guard ①, Floorboard assembly, and Brake Master Cylinder are properly aligned, then tighten all mounting bolts to the torque specifications shown.

#### **WARNING**

Verify proper brake operation before motorcycle operation. Brake malfunction could lead to an accident which could result in personal injury or death.

#### **CARE AND CLEANING**

Refer to your Owner's Manual.

#### **CUSTOMER SERVICE**

For more information regarding installation, please contact your Yamaha dealer.