

**ENGINE GUARD KIT**  
**INSTALLATION INSTRUCTIONS**  
**STR-5EL31-00-00**  
**XVS1100 ("V STAR 1100")**



**INTRODUCTION**

Please read and understand these instructions completely before installation to avoid any possible injury to yourself or damage to your motorcycle and/or accessory.

**DEALER:** These instructions contain important information for future reference and must be given to the customer.

PARTS LIST			
Item	Part Name	Description	Qty
①	Engine Guard, Left		1
②	Engine Guard, Right		1
③	Spacer	Aluminum, 19.1mm OD x 10mm thick	2
④	Spacer	Aluminum, 15.9mm OD x 4.8mm thick	2
⑤	Bolt, Hex Head Flange	M10 x 1.25p x 70mm long	2
⑥	Bolt, Hex Head Flange	M10 x 1.25p x 20mm long	2
⑦	Bolt, Button Head	M8 x 1.25p x 20mm long	2
⑧	Bolt	Stock part	REF.
⑨	Bolt	Stock part	REF.

**INSTALLATION**

**CAUTION:**

Work on one side at a time. Installation procedures include removing engine mounting bolts. If the bolts are removed on both sides at one time, the engine can move downward.

1. Place the motorcycle securely on the side-stand.
2. Remove the two bolts holding the left rider footpeg assembly to the frame. These bolts will be reused.

**NOTE:** It is not necessary to disconnect the shift linkage.

3. Remove the two bolts holding the left side of the front cylinder head to the frame. Store these bolts in case the Engine Guard is removed later.
4. Position the two wider Spacers ③ behind the upper mounting holes of the left Engine Guard ①, then install the two new bolts ⑤ through the guard and spacers into the frame. Loosely tighten the bolts.

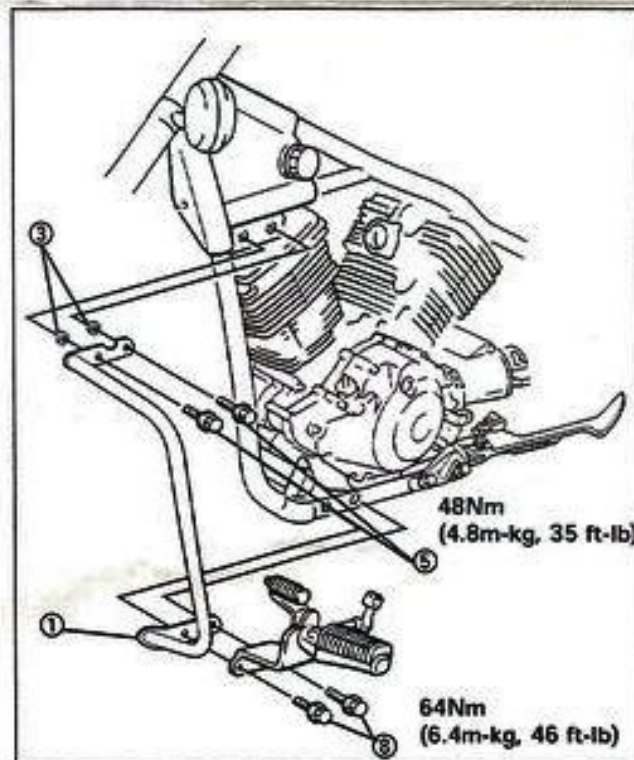

5. Reinstall the left rider footpeg assembly with the lower engine guard mount between the frame and the footpeg. Reinstall the stock mounting bolts (8). Be sure the Engine Guard (1) is properly aligned, then tighten all mounting bolts to the torque specification shown.

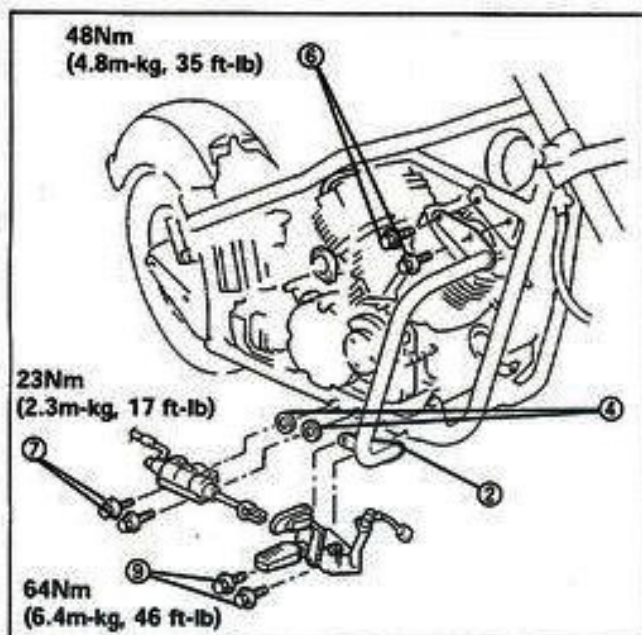

6. Remove the two bolts holding the right rider footpeg assembly to the frame. These bolts will be reused. Also remove the two bolts holding the rear brake master cylinder bracket to the frame. Store the master cylinder bracket mounting bolts in case the engine guard is removed later.

**NOTE:** Do not disconnect the footpeg assembly from the master cylinder or disconnect the brake switch lead wires.

7. Remove the two bolts which hold the right side of the front cylinder head to the frame. Store these bolts in case the engine guards is removed later.

8. Hold the right Engine Guard (2) in position on the frame, then install the two new Bolts (6) through the guard into the frame. Loosely tighten the bolts.
9. Reinstall the right footpeg assembly using the stock mounting bolts (9). Loosely tighten the bolts.

#### **⚠ WARNING**

Be sure the brake switch lead wires are not pinched or under strain.

10. Position the two narrower Spacers (4) between the brake master cylinder bracket and the frame. Install the two new Bolts (7). Be sure the Engine Guard (2), footpeg assembly, and brake master cylinder are properly aligned, then tighten all mounting bolts to the torque specifications shown.

#### **⚠ WARNING**

Verify proper brake operation before motorcycle operation. Brake malfunction could lead to an accident which could result in personal injury or death.

### **CARE AND CLEANING**

Refer to your Owner's Manual.

### **CUSTOMER SERVICE**

For more information regarding installation, please contact your Yamaha dealer.